

ASSY: ---- 4

THIS DOCUMENT MAY CONTAIN INFORMATION AFFECTING THE NATIONAL DEFENSE OF THE UNITED STATES WITHIN THE MEANING OF THE ESPIONAGE ACT, OR MAY REPRESENT A PROPRIETARY ARTICLE TO WHICH SNAP-TITE, INC. RETAINS THE EXCLUSIVE RIGHT OF MANUFACTURE AND SALE. THIS DOCUMENT IS DISCLOSED IN CONFIDENCE, AND ITS POSSESSION DOES NOT CONVEY PERMISSION TO MANUFACTURE THE ARTICLE DEPICTED HEREIN. SUCH PERMISSION MAY BE GRANTED ONLY BY SPECIFIC AUTHORIZATION IN WRITING, SIGNED BY AN OFFICER OF SNAP-TITE, INC.

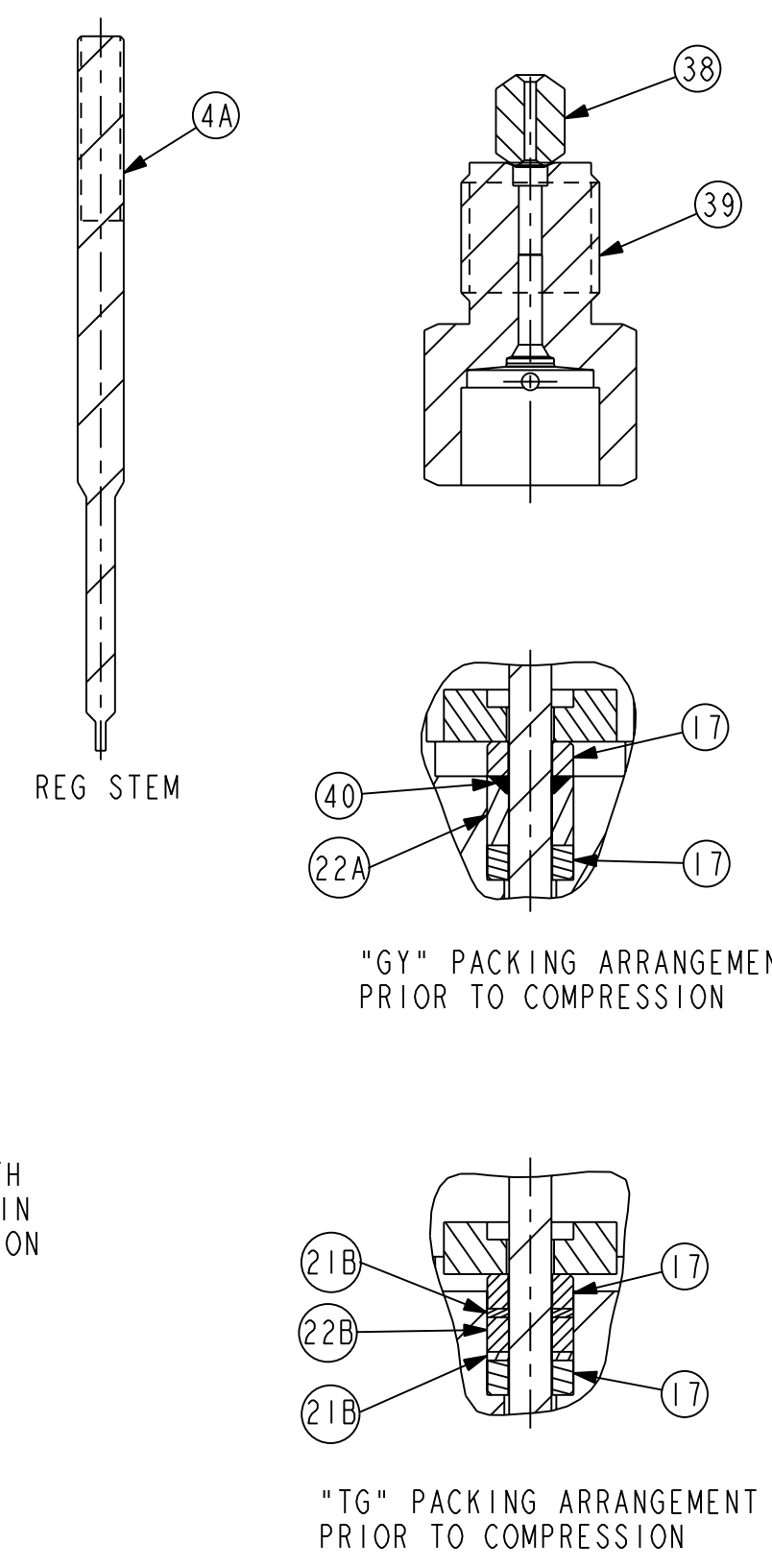
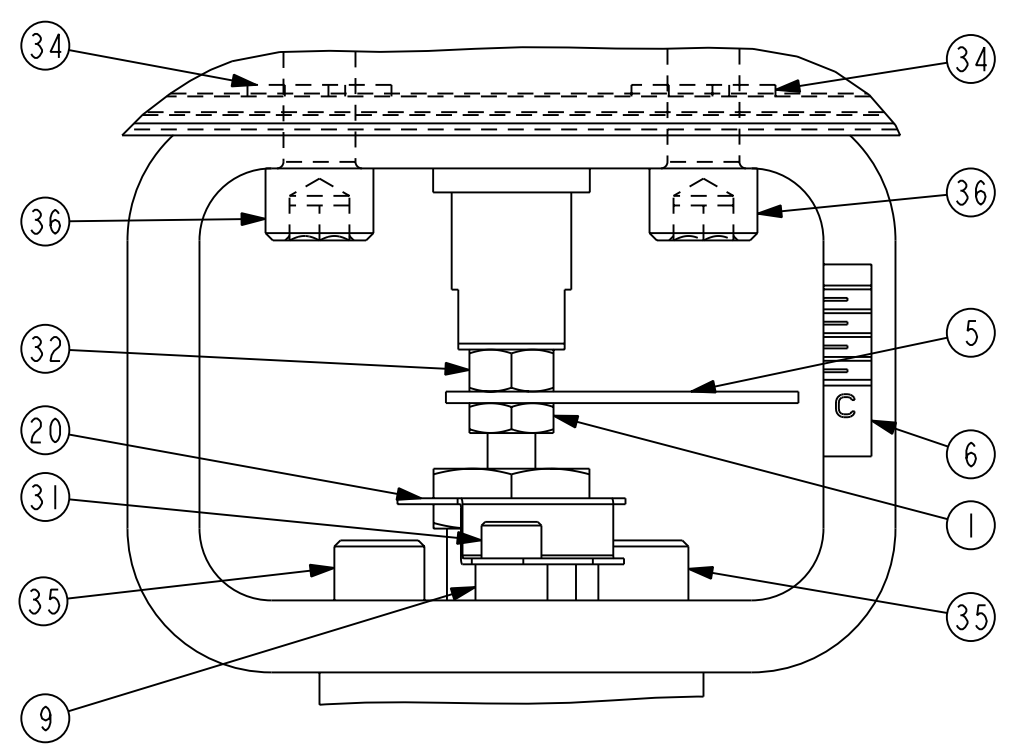
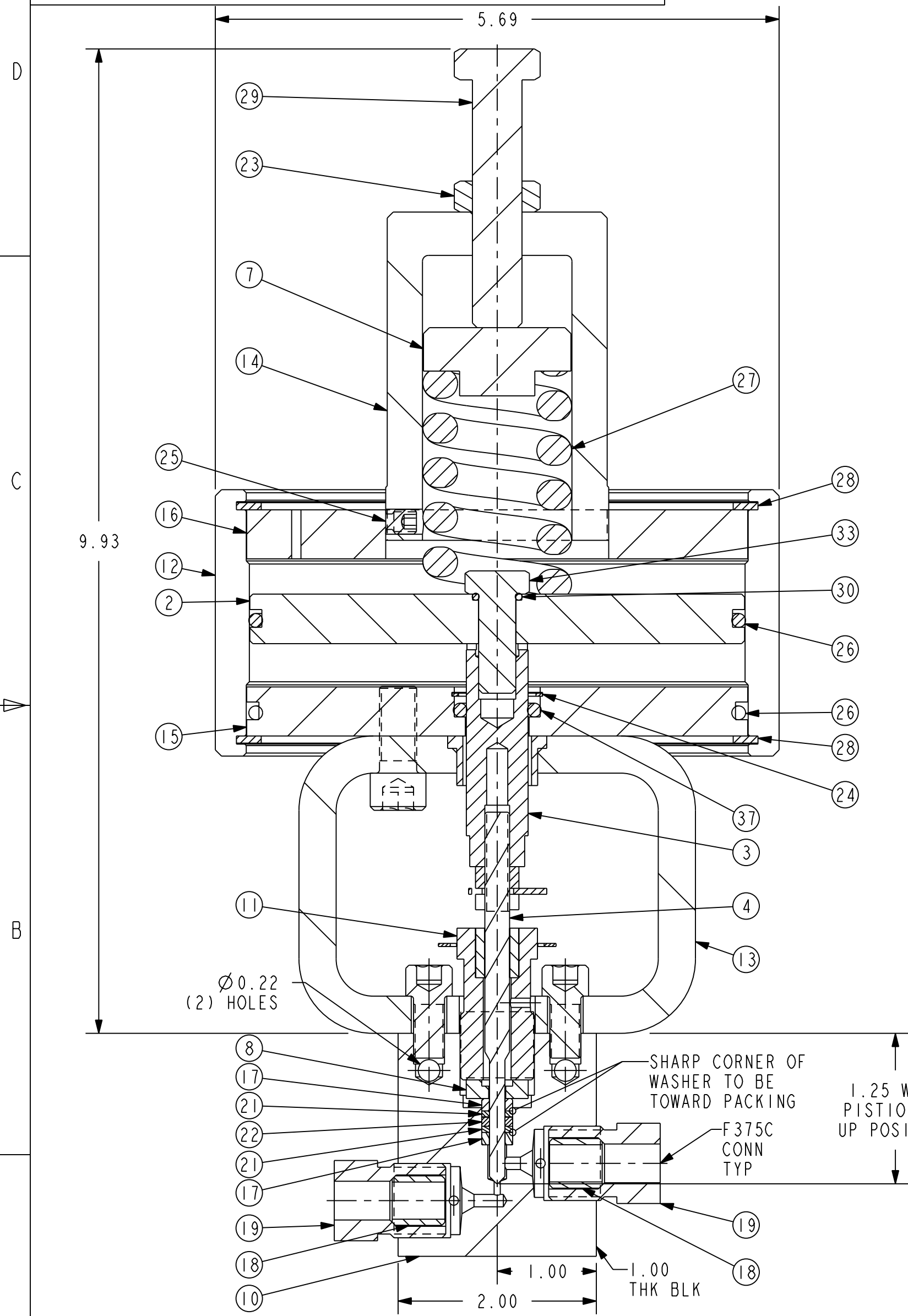

#	REVISION	BY: RPB	APP
4	REDRAWN; ADDED -GY & -TG PACKING ARRANGEMENT	DATE: 10/7/10	SAJ
		BY:	
		DATE:	

DESCRIPTION	BODY P/N	STEM TYPE	CATALOG NUMBER	STEM P/N
2 STEM MANIFOLD	2020-6457-YB	REG	60VM6085-OIS	101C-3928
2 WAY ANGLE REPLACEABLE SEAT	2020-6454-YB	VEE	60VM6075-OIS	101C-0475
		REG	60VM6882-OIS	101C-3928
3 WAY 1 ON PRESSURE	2020-6455-YB	VEE	60VM6872-OIS	101C-0475
		REG	60VM6084-OIS	101C-3928
3 WAY 2 ON PRESSURE	2020-6452-YB	VEE	60VM6074-OIS	101C-0475
		REG	60VM6083-OIS	101C-3928
2 WAY ANGLE	2020-6456-YB	VEE	60VM6072-OIS	101C-0475
		REG	60VM6082-OIS	101C-3928
2 WAY STRAIGHT	2020-6453-YB	VEE	60VM6081-OIS	101C-3928
		REG	60VM6071-OIS	101C-0475

MAX ALLOW WORKING PRESSURE: 60,000 PSI @ RT
 HYDROTEST PRESSURE: 75,000 PSI @ RT
 MAX ALLOW AIR PRESSURE: 100 PSI
 AIR PRESSURE REQD FOR OPERATION: 60 PSI
 PACKING GLAND TORQUE: 60 FT-LBS
 SEAT RETAINER TORQUE: 30 FT-LBS
 APPROX SPRING COMPRESSION AT MAX VALVE RATING: 0.38
 APPROX STEM LIFT AT MAX VALVE RATING: 0.25
 ALLOWABLE PISTON TEMP: -20°F TO 200°F
 AREA OF PISTON: 19.6 SQ IN.

#PER TABLE ABOVE
 *AS REQUIRED

Top Level Assembly BOM				
ITEM NO	QTY	PART No.	Description	Material
1	1	90550	HEX JAM NUT 1/4-28	STEEL ZINC PLATED
2	1	101B-9018	PISTON	ALUM
3	1	101C-0456	SHAFT	316 SS
4	1	101C-0475	VEE STEM	17-4
5	1	101C-0484	INDICATOR	300 SERIES SS
6	1	101C-0494	STEM POSITION DECAL	PLASTIC
7	1	1020-8912	SPRING SUPPRESSOR	C STEEL
8	1	1020-9447	BACK-UP WASHER	17-4PH
9	1	105A-2577	SPACER	304 SS
10	1	2020-6453-YB	VALVE BODY 3/8" 60VM	316 SS
11	1	202B-4929	PACKING GLAND ASSM	316 SS
12	1	301A-3640	HOUSING	ALUMINUM
13	1	301A-3641	YOKE ASSM	STEEL
14	1	3050-4752	SPRING HOUSING	ALUMINUM
15	1	305A-3639	BOTTOM COVER ATO	ALUM
16	1	306A-3639	TOP COVER ATO	ALUM
17	2	3130-1477	PACKING WASHER	17-4PH
18	2	ACL60	COLLAR	316 SS
19	2	AGL60	GLAND	316 SS
20	1	P-0323	LOCKING DEVICE	302 SS
21	2	P-0829	PACKING	NYLON
22	1	P-0830	PACKING	LEATHER
23	1	P-0878	HEX JAM NUT 1/2-13	STEEL
24	1	P-1391	RETAINING RING	C'STL
25	1	P-1718	HEX SOC SET SCREW, 1/4-20 X 0.31 LG, HDQG	STEEL
26	2	P-1720	O-RING UNIF #248	TFE. COATED
27	1	P-1723	SPRING 1 1/2 X 2 1/2 EHD 368LB / 1/8	CHROME-VANADIUM
28	2	P-1724	RETAINING RING	C'STL
29	1	P-1733	SCREW, HEX HD CAP, 1/2-13 X 2.50 LG	Cd PLATED STEEL
30	1	P-1834	O-RING UNIF #012, 90 DURO	BUNA-N
31	1	P-1995	SOC HD CAP SCREW, #10-24 X 0.38 LG	18-8 SS
32	1	P-3289	HEX NUT, 1/4-28	STEEL
33	1	P-3510	SCREW, HEX HD CAP, 3/8-16 X 1.00 LG	STEEL
34	2	P-8918	THREAD SEAL	BUNA-N/STEEL
35	2	P-8920	SOC HD CAP SCREW, 5/16-24 X 0.62 LG	ALLOY STEEL
36	2	P-8921	SOC HD CAP SCREW, 3/8-16 X 0.88 LG	ALLOY STEEL
37	1	P-8922	O-RING UNIF #208	BUNA-N
38	1	101B-1387	REPLACEABLE SEAT	17-4PH
39	1	101C-5962	SEAT RETAINER	316 SS

Optional Parts List					
ITEM No.	QTY	PART No.	Description	Material	Cat# Suffix
22A	1	P-8933	PACKING	GRAPHITE YARN 0°F TO 800°F	-GY
40	1	101A-5589	WEDGE RING	BERYLCO	-GY
21B	2	90865	PACKING	PEEK	-TG
22B	1	P-8713	PACKING	TEFLON GLASS 0°F TO 600°F	-TG
4B	1	102C-0475-C	VEE STEM	N-DURA	-CS
4C	1	104C-0475	VEE STEM	STELLITE	-STS
38A	1	105B-1387-C	REPLACEABLE SEAT	N-DURA	-CSS
38B	1	102B-1387	REPLACEABLE SEAT	STELLITE	-SRS

P/N: 60VM6XXX-OIS
 MATERIAL: 316 SS
 P/S: - REF PART: NONE
 DWN: BMH 6/24/87 APPVD: SGR
 DO NOT SCALE DRAWING

AT Snap-tite, Inc. - Erie, Pennsylvania, U. S. A.
 Autoclave Engineers Division

AIR OPERATED VALVE ASSEMBLY
 3/8" 60VM-OIS

SIZE: C EWO: STD DWG. NO.: 30A-0615 REV: 4
 SCALE: 15:16 H4-1 CODE: 78357 SHEET: 1 OF 1

CONTROL DRAWING