

DETAIL A
SCALE 2.000
60-11HF4-NO

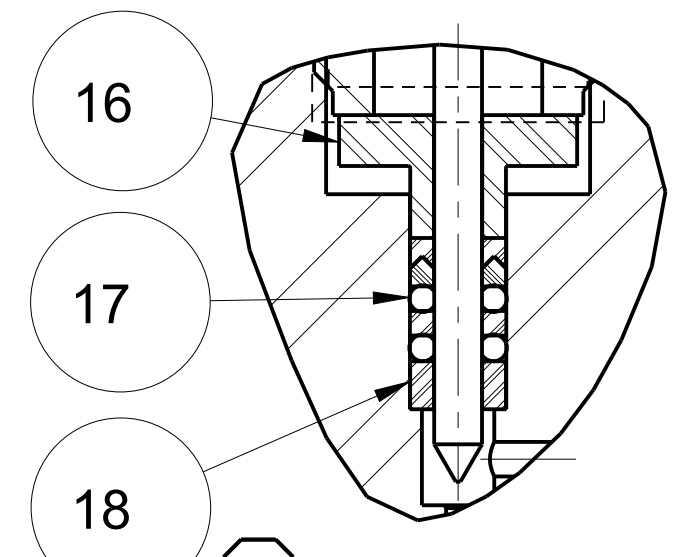

DETAIL A
SCALE 2.000
60-11HF4-NO-212401

60-11HF4-NO BILL OF MATERIAL				
ITEM	QTY	DESCRIPTION	PART NO.	MATERIAL
1	1	ADAPTER PLUG	207531	2024-T4 ALUM
2	1	1/4-28 HEX NUT	B01354	STEEL
3	1	SUPPORT WASHER	207526	2024
4	2	SNAP RING	B01351	STEEL
5	2	O-RING UNIF #145	B01350	BUNA-N
6	2	DIAPHRAGM HOUSING	402342	TENZALLOY
7	8	HEX HEAD CAP SCREW	B00278	STEEL
8	8	5/16-18 HEX NUT	B00291	STEEL
9	1	DIAPHRAGM SUPPORT	208223	TENZALLOY
10	1	DIAPHRAGM	B01356	NYLON_REINFORCED_NEOPRENE
11	1	SPRING	B00395	STEEL
12	1	HOUSING ADAPTER	207532	2024-T4 ALUM
13	1	HIPCO GLAND	207525	300_SERIES_SST
14	1	3/4-16 JSM NUT	B01225	STEEL
15	1	STEM ASSEMBLY	209426	17-4PH H900/H1150
16	1	TOP PACKING WASHER	200717	17-4_PH_H900
17	1	PACKING SET	214089	TEFLON/NYLATRON
18	1	BOTTOM WASHER	200716	17-4_PH_H900
19	1	VALVE BODY	200721	316
20	2	COLLAR	60-2H4	316
21	2	GLAND	60-2HM4	316

FOR 60-11HF4-NO-212401 REPLACE ITEM 17 WITH THE FOLLOWING				
17	1	PACKING SET	212401	TEFLON/VITON/NYLON



PACKING GLAND TORQUE 40 FT LB

STANDARD TOLERANCES AND MANUFACTURING PRACTICES SPECIFICATION ES-002 APPLIES TO THIS DRAWING.	STANDARD TOLERANCES		DISTRIBUTION OR REPRODUCTION OF THIS DOCUMENT IS PROHIBITED WITHOUT WRITTEN PERMISSION FROM HIGH PRESSURE EQUIPMENT A GRACO COMPANY	HIGH PRESSURE EQUIPMENT A GRACO CO. ERIE PENNSYLVANIA USA	
	X.XXX± 0.005			TITLE	
	X.XX± 0.01			HIPCO VALVE ASY NORMALLY OPEN	
FRACTIONAL ± 1/64		SHEET 1 OF 1		602006	
2	SR 23-0351 212401	2023-10-18	JY	DRAWN BY: DF	2000-08-08
REV	REVISION	DATE	BY		